

## Soil TH & TH-EC Sensor Manual

### Soil parameters measuring

Temperature	<ul style="list-style-type: none"><li>• Measuring range: -40°C-80°C</li><li>• Accuracy: <math>\pm 0.5^{\circ}\text{C}</math> (25°C)</li><li>• Long-term stability: <math>\leq 0.1\% ^{\circ}\text{C}/\text{y}</math></li><li>• Response time: <math>\leq 15\text{s}</math></li></ul>
Humidity	<ul style="list-style-type: none"><li>• Measuring range: 0-100%RH</li><li>• Accuracy: 3% within 0-50%, 5% within 50-100%</li><li>• Long-term stability: <math>\leq 1\% \text{RH}/\text{y}</math></li><li>• Response time: <math>\leq 4\text{s}</math></li></ul>
Conductivity (EC)	<ul style="list-style-type: none"><li>• Measuring range: 0-20000us/cm</li><li>• Accuracy: 0-10000 us/cm range is <math>\pm 3\%</math>; 10000-20000 us/cm range is <math>\pm 5\%</math></li><li>• Long-term stability: <math>\leq 1\% \text{uS}/\text{cm}</math></li><li>• Response time: <math>\leq 1\text{s}</math></li></ul>

### Specification

Power supply	DC4.5-30V
Max Power consumption	0.5W@24V DC
Protection class	IP68, long-term immersion in water use
Cable length	2M
Operating environment	-40°C-80°C
Overall dimensions	45 * 15 * 123mm

### Size

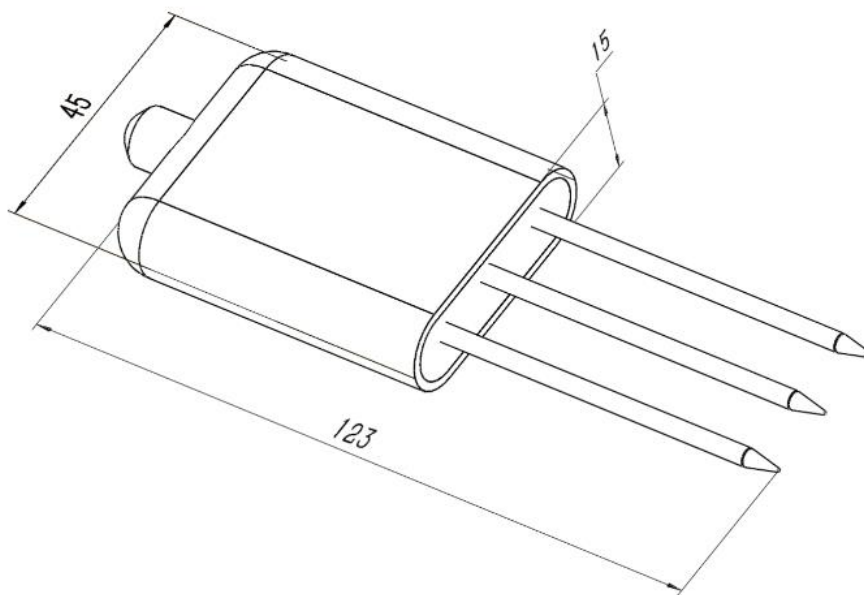

## Wiring

Cable color	description
Brown	Power + (DC5-30V)
black	Power -
yellow	RS485 A+
blue	RS485 B-

## Measuring range

$\varphi=5\text{cm}$



## Installation

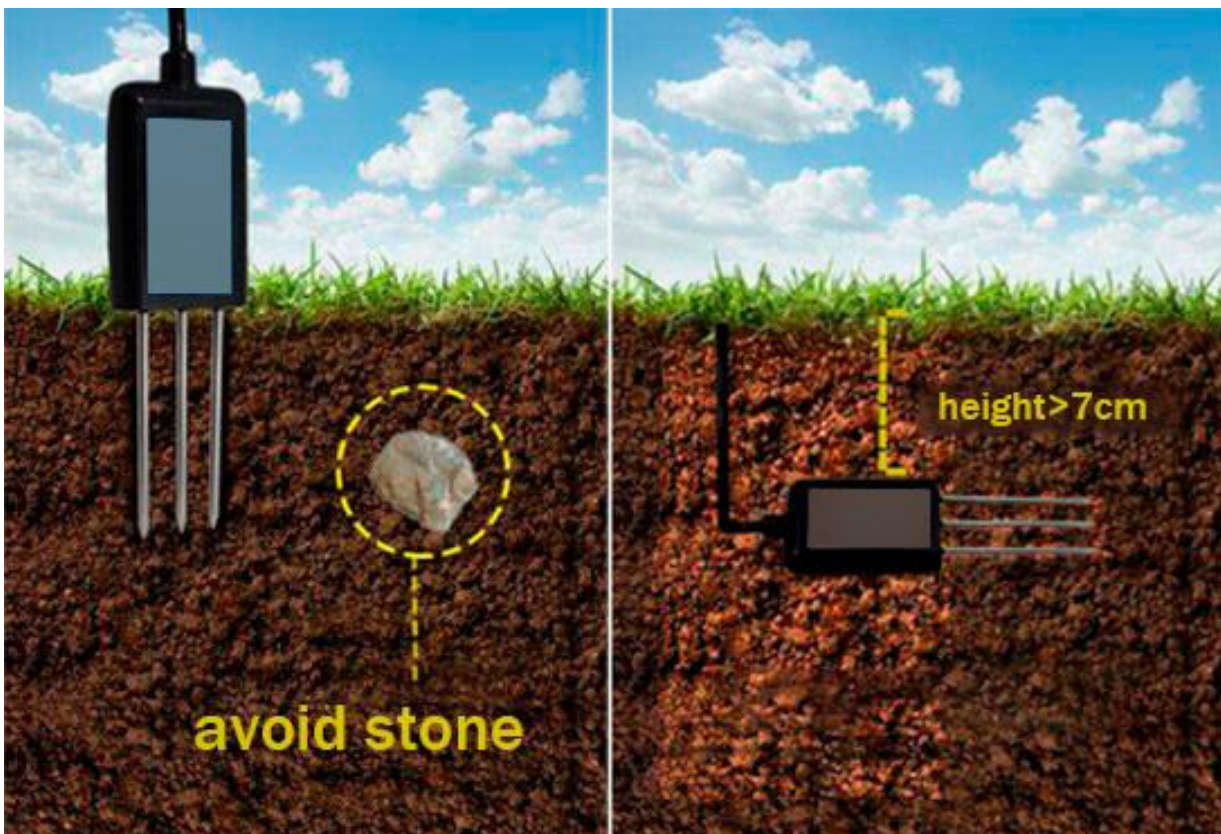

## RS485 communication

Default parameters: 4800,n,8,1

Default device address is 1

Modbus RTU protocol

Read status registers, read function code: 0x30					
Register address (Hex)	PLC Address (decimal)	meaning	Number of bytes	content	remark
0000	40001	Humidity	2	0.1%RH	read
0001	40002	Temperature	2	0.1 °C	read
0002	40003	Conductivity	2	1	read
0003	40004	Salinity	2	1	read
0004	40005	TDS	2	1	read
0022	40035	Conductivity factor	2	0-100 correspond to 0.0%-10.0% Default 0.0%	read / write
0023	40036	Salinity factor	2	0-100 correspond to 0.00-1.00 Default 55 (0.55)	read / write
0024	40037	TDS factor	2	0-100 correspond to 0.00-1.00 Default 50 (0.5)	read / write
0050	40081	Temperature offset	2	0.1	read / write
0051	40082	Humidity offset	2	0.1	read / write
0052	40083	Conductivity offset	2	1	read / write
Parameters registers, read function code: 0x30, write function code: 0x06					
07D0	42001	Slave ID	2		1-254
07D1	42002	baud rate	2		0: 2400 1: 4800 2: 9600 Default 4800

E.g., read Humidity, temperature, conductivity together:

Master sends

Address	Function Code	Start Address (Hi)	Start Address (Lo)	Number of Points (Hi)	Number of Points (Lo)	Error Check (Lo)	Error Check (Hi)
0x01	0x03	0x00	0x00	0x00	0x03	0x05	0xCB

Sensor responds:

Address	Function Code	Number of byte	humidity value	temperature value	conductivity value	Error Check (Lo)	Error Check (Hi)
0x01	0x03	0x06	0x02 0x92	0xFF 0x9B	0x03 0xE8	0x38	0x75

Temperature calculates:

When temperature less than 0, value will be responded in complement

Temperature: FF9B H= -101 => temperature= -10.1°C

Humidity: 292 H= 658 => humidity= 65.8%

Conductivity: 3E8 H= 1000 => Conductivity = 1000 us/cm

### Set slave ID

E.g., set slave ID=2, Master sends

Address	Function Code	Start Address (Hi)	Start Address (Lo)	ID	Error Check (Lo)	Error Check (Hi)
0x01	0x06	0x07	0xD0	0x00 0x02	0x08	0x86

Sensor responds:

Address	Function Code	Start Address (Hi)	Start Address (Lo)	ID	Error Check (Lo)	Error Check (Hi)
0x01	0x06	0x07	0xD0	0x00 0x02	0x08	0x86

### Set baud rate

E.g., set baud rate to 9600, Master sends

Address	Function Code	Start Address (Hi)	Start Address (Lo)	command	Error Check (Lo)	Error Check (Hi)
0x01	0x06	0x07	0xD1	0x00 0x02	0x59	0x46

Sensor responds:

Address	Function Code	Start Address (Hi)	Start Address (Lo)	command	Error Check (Lo)	Error Check (Hi)
0x01	0x06	0x07	0xD1	0x00 0x02	0x59	0x46

## Enquiry slave ID

Master sends

Address	Function Code	Start Address (Hi)	Start Address (Lo)	Number of Points (Hi)	Number of Points (Lo)	Error Check (Lo)	Error Check (Hi)
0xFF	0x03	0x07	0xD0	0x00	0x01	0x91	0x59

Sensor responds:

Address	Function Code	Number of Points	address	Error Check (Lo)	Error Check (Hi)
0xFF	0x03	0x02	0x00 0x01	0x50	0x50