

Soil TH-NPK & TH-PH-NPK & TH-EC-NPK & TH-EC-PH-NPK sensor manual

Soil parameters measuring

Temperature	<ul style="list-style-type: none"> • Measuring range: -40°C-80°C • Accuracy: ±0.5°C (25°C) • Long-term stability: ≤0.1%°C/y • Response time: ≤15s
Humidity	<ul style="list-style-type: none"> • Measuring range: 0-100%RH • Accuracy: 3% within 0-50%, 5% within 50-100% • Long-term stability: ≤1%RH/y • Response time: ≤4s
Conductivity (EC)	<ul style="list-style-type: none"> • Measuring range: 0-20000us/cm • Accuracy: 0-10000 us/cm range is ±3%; 10000-20000 us/cm range is ±5% • Long-term stability: ≤1%uS/cm • Response time: ≤1s
PH	<ul style="list-style-type: none"> • Measuring range: 3-9 PH • Accuracy: ±0.3PH • Long-term stability: ≤5%/year • Response time: ≤10S
Nitrogen Phosphorus Potassium	<ul style="list-style-type: none"> • Measuring range: 1-2999 mg/kg(mg/L) • Resolution: 1 mg/kg(mg/L) • Response time: <1S
<p>Reminder The measurement of NPK adopts the general rapid detection method, so there are certain errors, Use with caution for planting reference. However, the sensor supports the function of writing NPK data. You can use standard instruments to measure NPK then write in to provide data for monitoring system.</p>	

Specification

Power supply	DC4.5-30V
Max Power consumption	0.5W@24V DC
Protection class	IP68, long-term immersion in water use
Cable length	2M
Operating environment	-40°C-80°C
Overall dimensions	45 * 15 * 123mm

Size

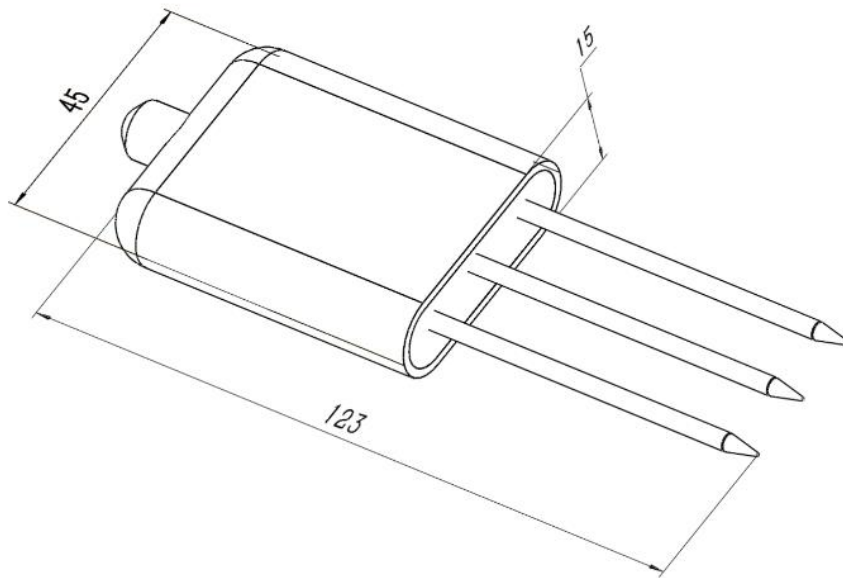

Wiring

Cable color	description
Brown	Power + (DC5-30V)
black	Power -
Yellow/Green	RS485 A+
blue	RS485 B-

Measuring range

$\varphi=5\text{cm}$



Installation

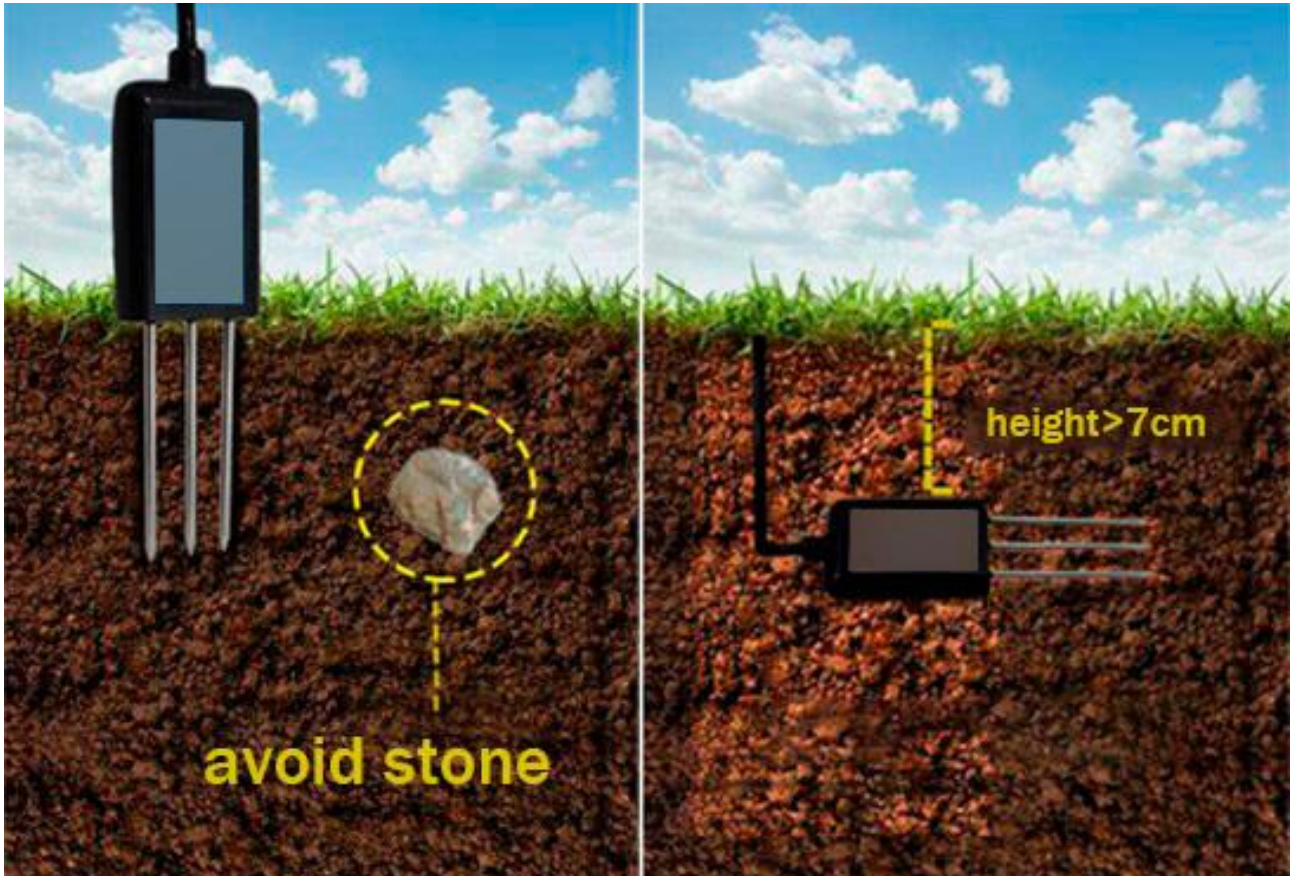

RS485 communication

Default device address is 1, RS485 Default parameters: 4800,n,8,1

Register map:

Read status registers, read function code: 0x30					
Register address (Hex)	PLC Address (decimal)	meaning	Number of bytes	content	remark
0000	40001	Humidity	2	0.1%RH	read
0001	40002	Temperature	2	0.1°C	read
0002	40003	Conductivity	2	1 us/cm	read
0003	40004	PH	2	0.1	read
0004	40005	Nitrogen (N)	2	1 mg/kg	read / write
0005	40006	Phosphorus (P)	2	1 mg/kg	read / write
0006	40007	Potassium (K)	2	1 mg/kg	read / write
0007	40008	Salinity	2	1 mg/L	read
0008	40009	TDS	2	1 mg/L	read
0022	40035	Conductivity factor	2	0-100 correspond to 0.0%-10.0% Default 0.0%	read / write
0023	40036	Salinity factor	2	0-100 correspond to 0.00-1.00	read / write

				Default 55 (0.55)	
0024	40037	TDS factor	2	0-100 correspond to 0.00-1.00 Default 50 (0.5)	read / write
0050	40081	Temperature offset	2	0.1	read / write
0051	40082	Humidity offset	2	0.1	read / write
0052	40083	Conductivity offset	2	1	read / write
0053	40084	PH offset	2	1	read / write
04E8	41257	Nitrogen(N) factor high byte	2	real value (float)	read / write
04E9	41258	Nitrogen(N) factor low byte	2		
04EA	41259	Nitrogen(N) offset	2		read / write
04F2	41267	Phosphorus(P) factor high byte	2	real value (float)	read / write
04F3	41268	Phosphorus(P) factor low byte	2		
04F4	41269	Phosphorus(P) offset	2		read / write
04FC	41277	Potassium(K) factor low byte	2	real value (float)	read / write
04FD	41278	Potassium(K) factor low byte	2		
04FE	41279	Potassium(K) offset	2		read / write
Parameters registers, read function code: 0x30, write function code: 0x06					
07D0	42001	Slave ID	2	1-254	read / write
07D1	42002	baud rate	2	0: 2400 1: 4800 2: 9600 Default 4800	read / write

Factor and offset like the formula

$$Y=AX+B$$

Y is reading value

X is original value

A is factor

B is offset

Read

E.g., Read Humidity, temperature, conductivity, PH, N, P, K together:

Master sends

Address	Function Code	Start Address (Hi)	Start Address (Lo)	Number of Points (Hi)	Number of Points (Lo)	Error Check (Lo)	Error Check (Hi)
0x01	0x03	0x00	0x00	0x00	0x07	0x04	0x08

Sensor responds:

Address	Function Code	Number of byte	humidity	temperature	conductivity	PH	N	P	K	Error Check (Lo)	Error Check (Hi)
0x01	0x03	0x0E	0x01 0xD0	0x01 0x4C	0x00 0x2C	0x00 0x5A	0x00 0x20	0x00 0x58	0x00 0x68	0x70	0x29

Temperature: 14C H= 332=> temperature= 33.2°C

Humidity: 1D0 H= 464 => humidity= 46.4%

Conductivity: 2C H= 44 => Conductivity = 44 us/cm

PH: 5A H= 56 => PH= 9

Nitrogen (N): 20 H= 56 => N= 32 mg/kg

Phosphorus (P): 58 H= 56 => P= 88 mg/kg

Potassium (K): 68 H= 104 => K= 104 mg/kg

Write Nitrogen (N)

E.g., write 32 into Nitrogen register, Master sends

Address	Function Code	Start Address (Hi)	Start Address (Lo)	N	Error Check (Lo)	Error Check (Hi)
0x01	0x06	0x00	0x04	0x00 0x20	0xC9	0xD3

Sensor responds:

Address	Function Code	Start Address (Hi)	Start Address (Lo)	N	Error Check (Lo)	Error Check (Hi)
0x01	0x06	0x00	0x04	0x00 0x20	0xC9	0xD3

Write Phosphorus (P)

E.g., write 88 into Phosphorus register, Master sends

Address	Function Code	Start Address (Hi)	Start Address (Lo)	P	Error Check (Lo)	Error Check (Hi)
0x01	0x06	0x00	0x05	0x00 0x58	0x98	0x31

Sensor responds:

Address	Function Code	Start Address (Hi)	Start Address (Lo)	P	Error Check (Lo)	Error Check (Hi)
0x01	0x06	0x00	0x05	0x00 0x58	0x98	0x31

Write Potassium (K)

E.g., write 104 into Potassium register, Master sends

Address	Function Code	Start Address (Hi)	Start Address (Lo)	K	Error Check (Lo)	Error Check (Hi)
0x01	0x06	0x00	0x06	0x00 0x68	0x68	0x25

Sensor responds:

Address	Function Code	Start Address (Hi)	Start Address (Lo)	K	Error Check (Lo)	Error Check (Hi)
0x01	0x06	0x00	0x06	0x00 0x68	0x68	0x25

Set slave ID

E.g., set slave ID=2, Master sends

Address	Function Code	Start Address (Hi)	Start Address (Lo)	ID	Error Check (Lo)	Error Check (Hi)
0x01	0x06	0x07	0xD0	0x00 0x02	0x08	0x86

Sensor responds:

Address	Function Code	Start Address (Hi)	Start Address (Lo)	ID	Error Check (Lo)	Error Check (Hi)
0x01	0x06	0x07	0xD0	0x00 0x02	0x08	0x86

Set baud rate

E.g., set baud rate to 9600, Master sends

Address	Function Code	Start Address (Hi)	Start Address (Lo)	command	Error Check (Lo)	Error Check (Hi)
0x01	0x06	0x07	0xD1	0x00 0x02	0x59	0x46

Sensor responds:

Address	Function Code	Start Address (Hi)	Start Address (Lo)	command	Error Check (Lo)	Error Check (Hi)
0x01	0x06	0x07	0xD1	0x00 0x02	0x59	0x46

Enquiry slave ID

Master sends

Address	Function Code	Start Address (Hi)	Start Address (Lo)	Number of Points (Hi)	Number of Points (Lo)	Error Check (Lo)	Error Check (Hi)
0xFF	0x03	0x07	0xD0	0x00	0x01	0x91	0x59

Sensor responds:

Address	Function Code	Number of Points	address	Error Check (Lo)	Error Check (Hi)
0xFF	0x03	0x02	0x00 0x01	0x50	0x50